

POWER SUPPLY

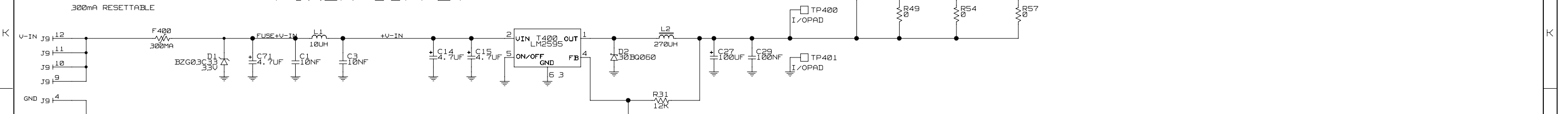

RS232

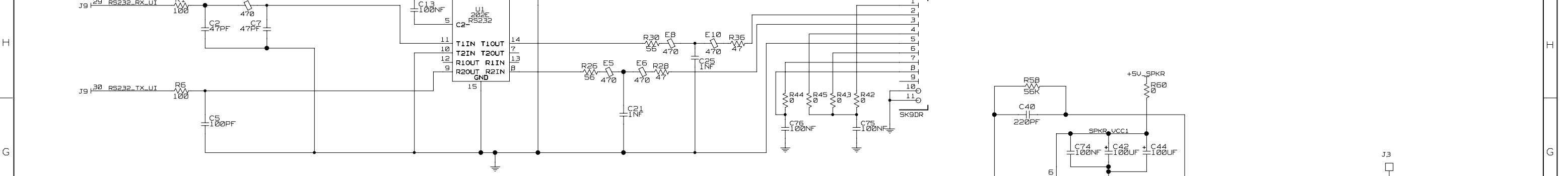

SPEAKER

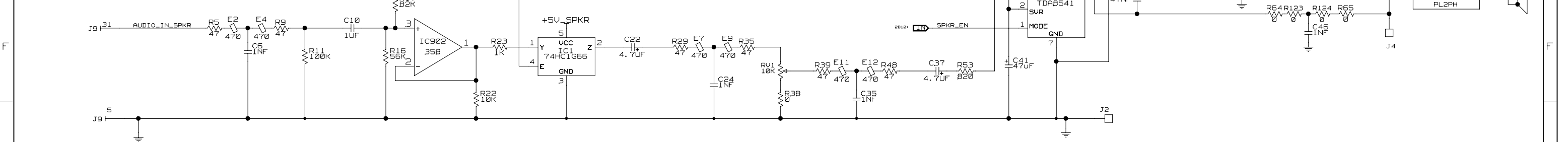

AMPLIFIER

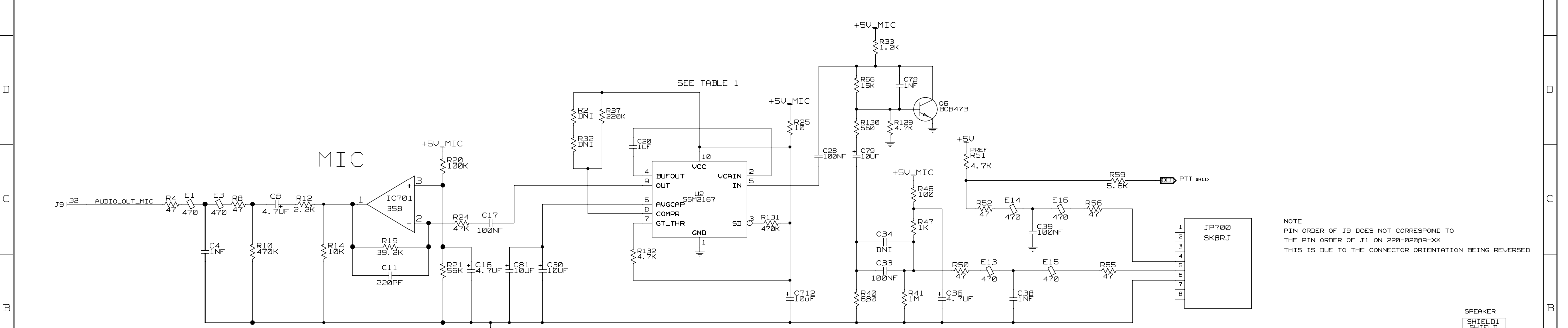

MIC

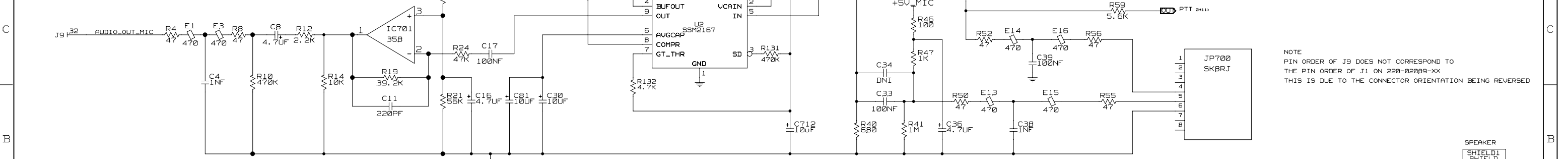

NOTE
PIN ORDER OF J9 DOES NOT CORRESPOND TO
THE PIN ORDER OF J1 ON 220-02089-XX
THIS IS DUE TO THE CONNECTOR ORIENTATION BEING REVERSED

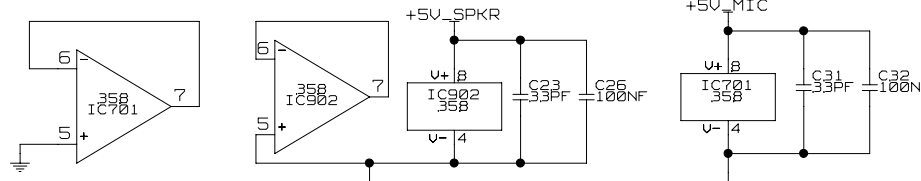
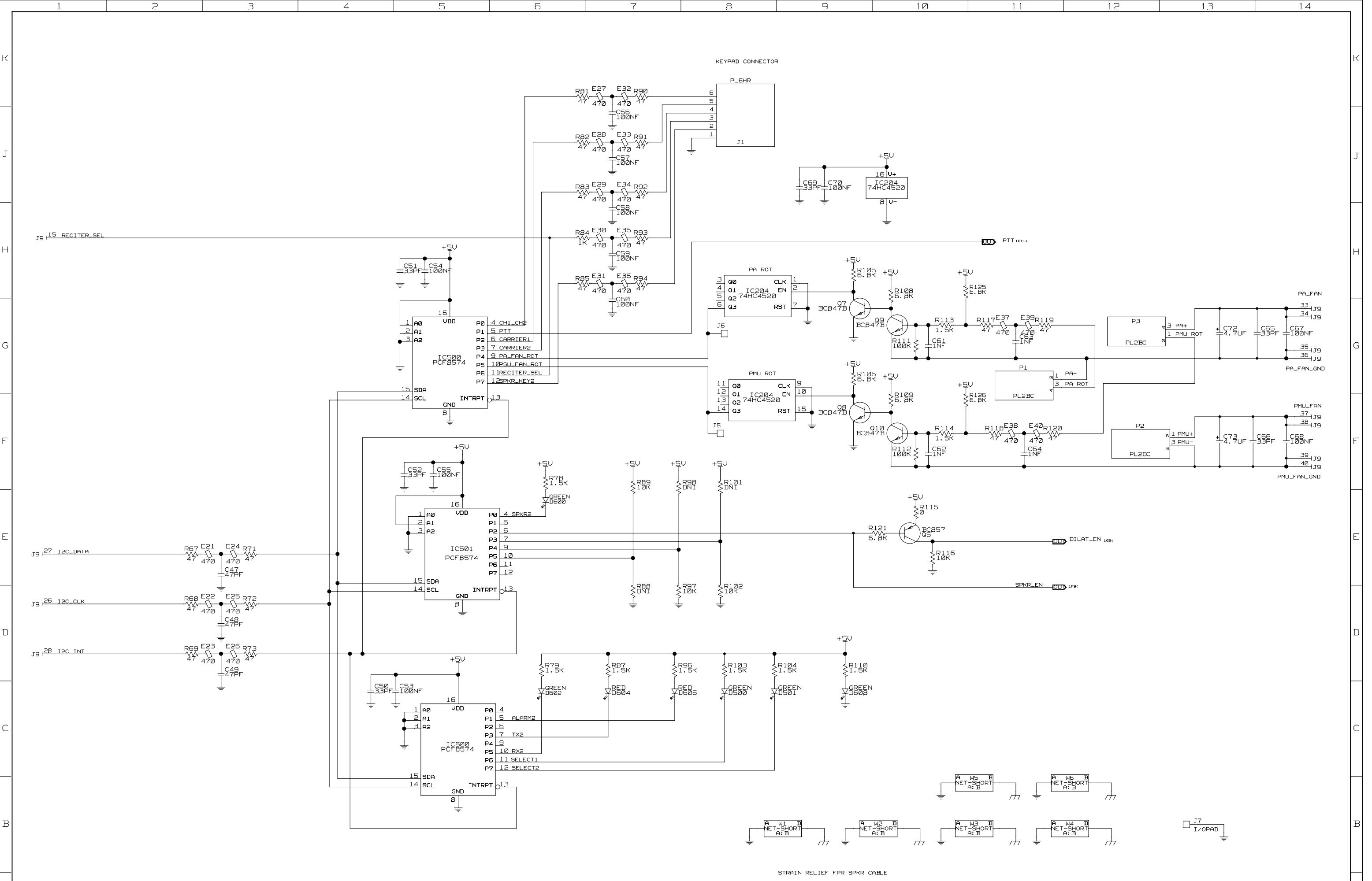

TABLE 1

MIC TYPE	
DYNAMIC	C34
ELECTRET	C33, R47

© TAIT ELECTRONICS A1
TB8100 UI
USER INTERFACE
IPN: 220-02069-04 ISSUE: A VARIANT NUMBER: ?
FILE DATE: Fri Jul 21 09:53:44 2006
ENGINEER: Alton Cooper FILE NAME: 220_02069 SHEET NUMBER: 1 OF 3

04A	VALUE CHANGES TRACK RE-ROUTING	ADAM. D	CHRIS K	DAVE E	GREG S	13JUL06
03A	DCO 02069-????	CHRIS K	CHRIS K	DAVE E	GREG S	24FEB06
02A	VALUE CHANGES	EDWIN T	CHRIS K	DAVE E	GREG S	24/01/06
01A	PROTOTYPE	ML	TB	CK	?	27-04-05
REV/ISS	AMENDMENTS	DRAWN	CHKD	D. O.	APVD	DATE



STRAIN RELIEF FPR SPKR CABLE

© TAIT ELECTRONICS		A1
TBB100 UI		
USER INTERFACE		
IPN:	ISSUE:	VARIANT NUMBER:
220-02069-04	A	?
FILE DATE: Tue Jul 25 14:48:33 2006		
ENGINEER:	FILE NAME:	SHEET NUMBER:
Alton Cooper	220_02069	2 OF 3

REV/ISS	AMENDMENTS	DRAWN	CHKD	D.O.	APVD	DATE
1						
2						
3						
4						
5						

